

## 3RD Right Angle Gearmotors | up to 148 lb-in.

- Unvented gearhousing for universal horizontal mounting
- Hardened worm gears
- Face-mount on the drive-shaft side, or bottom-mount is standard
- *42A-5H only*: Single and double shaft configurations available
- See Page 36 for capacitors and terminal boxes
- See page 43 for reference dimensions

### Variable Speed—Pacesetter Inverter Duty AC Gearmotors



Type 30R-3RD  
Inverter Duty

Fixed Speed Rating					Variable Speed (SOA) Ratings <sup>1</sup>						Product Type	230V Model Number
Speed (rpm)	Torque (lb-in.)	Motor HP	A	Gear Ratio	Speed Range (rpm)	Frequency Range (Hz)	Torque Type	Torque @ 10 Hz (lb-in.)	Torque @ 60 Hz (lb-in.)	Torque @ 90 Hz (lb-in.)		
0.5	95	1/25	0.38	3600	0.1-0.6	10-90	Constant	95	95	95	30R2BEPP-3RD	8036
1.2	126	1/25	0.38	1400	0.2-1.5			121	121	121	30R2BEPP-3RD	8014
2.8	148	1/17	0.48	600	0.2-3.6			148	148	148	30R4BEPP-3RD	8006
5.7	146	1/17	0.48	300	0.4-7.2			146	146	146	30R4BEPP-3RD	8003
8.5	141	1/17	0.48	200	0.7-0.11			141	141	141	30R4BEPP-3RD	8002

### Fixed Speed—AC Gearmotors



Type 30R-3RD

Speed (rpm)	Rated Torque (lb-in.)	Motor HP	V	Hz	Ph	Amps	Gear Ratio	Radial Load (lbs.)	Capacitor (µF/VAC)	Product Type	Model Number
<b>Permanent Split Capacitor, Non-synchronous</b>										<b>CAPACITOR IS REQUIRED</b>	
0.4	95	1/30	115	60	1	0.5	3600	160	5.0/250	30R2BECI-3RD	8536
1.1	126	1/30				0.5	1400		5.0/250	30R2BECI-3RD	8514
2.6	148	1/27				0.49	600		9.0/250	30R4BECI-3RD	8506
5.2	101	1/27				0.49	300		9.0/250	30R4BECI-3RD	8503
7.8	88	1/27				0.49	200		9.0/250	30R4BECI-3RD	8502

### Permanent Magnet DC Gearmotors



Type 24A-3RD

Speed (rpm)	Rated Torque (lb-in.)	24V Rated Current (A)	130V Rated Current (A)	Motor HP	FF	Gear Ratio	Radial Load (lbs.)	Product Type <sup>2</sup>	24V Model Number	130V Model Number
0.7	95	1.8	—	1/25	1.0	3600	160	24A2BEPM-3RD	4336	—
0.7	95	—	0.3	1/29		3600		24A2BEPM-3RD	—	4036
1.8	126	1.8	—	1/25		1400		24A2BEPM-3RD	4314	—
1.8	126	—	0.3	1/29		1400		24A2BEPM-3RD	—	4014
4.2	147	2.6	0.48	1/17		600		24A4BEPM-3RD	4306	4006
8.3	108	2.6	0.48	1/17		300		24A4BEPM-3RD	4303	4003
12.5	92	2.6	0.48	1/17	200	24A4BEPM-3RD	4302	4002		

### Brushless DC Gearmotors



Type 22B-3RD

Speed (rpm)	Rated Torque (lb-in.)	24V Rated Current	130V Rated Current	Motor HP	Gear Ratio	Radial Load (lbs.)	Product Type <sup>2</sup>	24V Model Number	130V Model Number
0.7	95	2.8	0.48	1/16	3600	160	22B2BEBL-3RD	5336	5036
1.8	126	2.8	0.48	1/16	1400		22B2BEBL-3RD	5314	5014
4.2	147	2.8	0.48	1/16	600		22B2BEBL-3RD	5306	5006
8.3	144	5.9	0.89	1/8	300		22B4BEBL-3RD	5303	5003
12.5	140	5.9	0.89	1/8	200		22B4BEBL-3RD	5302	5002

## 5H Right Angle Gearmotors | up to 296 lb-in.

### Variable Speed—Pacesetter Inverter Duty AC Gearmotors



Type 48R-5H  
Inverter Duty

Fixed Speed Rating					Variable Speed (SOA) Ratings <sup>1</sup>						Product Type	230/460V Model Number
Speed (rpm)	Torque (lb-in.)	Motor HP	(230/460V) Amps	Gear Ratio	Speed Range (rpm)	Frequency Range (Hz)	Torque Type	Torque @ 10 Hz (lb-in.)	Torque @ 60 Hz (lb-in.)	Torque @ 90 Hz (lb-in.)		
<b>Three-Phase, Inverter Duty, Non-synchronous (TEFC)</b>												
35	296	3/4	2.7/1.3	48	3.3-48	10-90	constant	272	272	272	48R6BFPP-5H	2280
47	285			36	4.4-63		constant	262	262	262		2281
94	256			18	8.9-127		constant	234	234	234		2282
170	178			10	16-228		variable	152	210	180		2283

### Permanent Magnet DC Gearmotors



Type 42A-5H

Speed (rpm)	Rated Torque (lb-in.)	Rated Current (Amps)		Peak Torque (lb-in.)	Motor HP	FF	Gear Ratio	Radial Load (lbs.)	Product Type <sup>2</sup>	Accy Shaft		No Accy Shaft	
		24V	130V							24V	130V		
<b>Single Shaft Gearmotor, Class B</b>													
52	189	12	2.3	340	1/3	1.0	48	150	42A7BEPM-5H	4829	4729	4599	4199
69	151			316			36			4828	4728	4598	4198
139	87			186			18			4827	4727	4596	4196
250	52			104			10			4826	4726	4594	4194
<b>Double Shaft Gearmotor, Class F</b>													
52	264	15	3.3	340	1/2	1.0	48	150*	42A7BEPM-5H	4833	4733	4503	4103
69	218			340			36	4832		4732	4502	4102	
139	129			286			18	4831		4731	4501	4101	
250	71			158			10	4830		4730	4500	4100	

\*only on one of the two shafts

Right Angle Gearmotor Dimensions

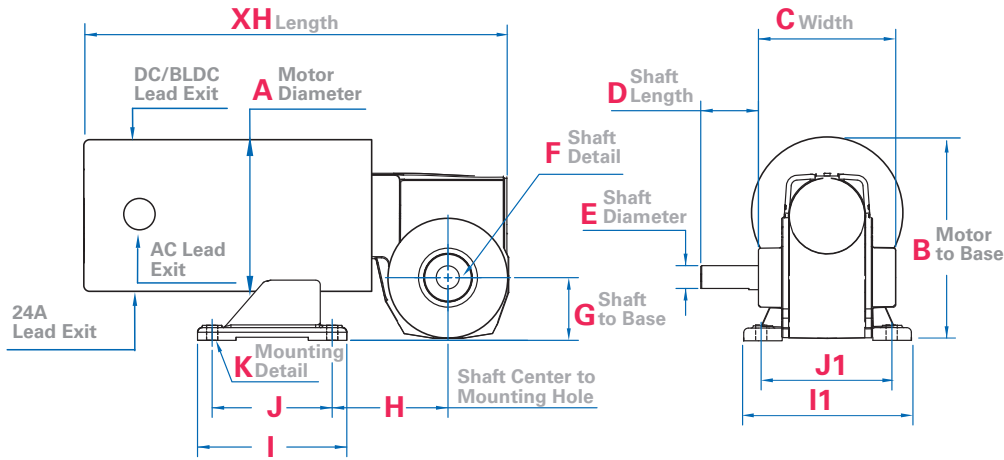

Gearhead Type 3F, 5R/5L, pages 14-16 (Mounts from Motor)

	Weight (lbs.)	XH Length	A Dia-meter	B Motor to Base	C Width	D Shaft Length	E Shaft Diameter	F Shaft Detail	G Shaft to Base	H Shaft Center To Mounting Hole	I Base Length	I1 Base Width	J Mounting Hole Length	J1 Mounting Hole Width	K Mounting Detail	Cord/Lead Length (in.)
<b>Type 3F Gearmotor</b>																
24A4-3F	5.3	7.422	2.42	3.57	2.871	1.00	.500	Flat	1.28	3.14	2.50	3.62	1.25	2.94	[4] ø.28	24
<b>Type 5R Gearmotor</b>																
34R4-5R	11.5	9.206	4.02	5.24	3.568	1.50	.625	Key/Flat	1.63	3.01	3.88	4.38	3.12	3.38	[4] ø.29	12
33A3-5R	9.0	8.651	3.39	4.92												24
<b>Type 5L Gearmotor</b>																
42R4-5L	13.5	9.54	4.73	5.57	3.568	1.50	.625	Key/Flat	1.56	2.856	4.38	5.02	3.62	4.00	[4] ø.30	12
42A4-5L	14.1	9.635	4.26	5.54												24

Right Angle Gearmotor Dimensions

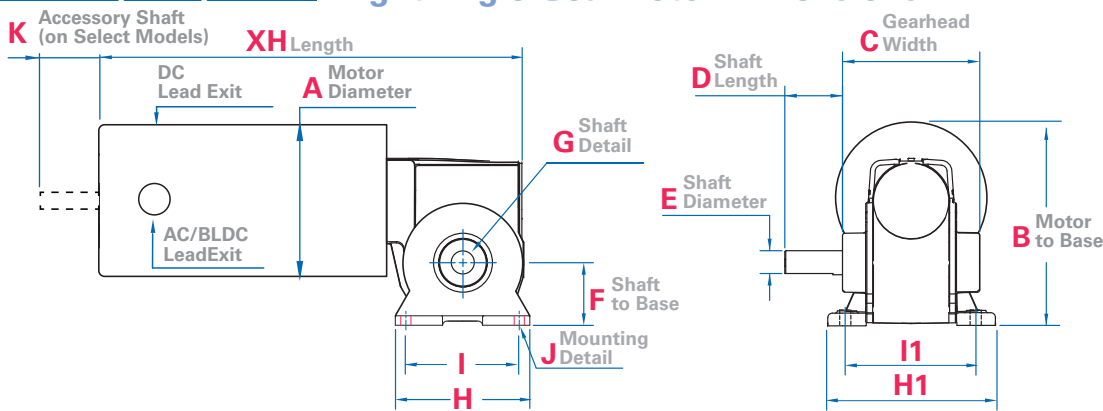

Gearmotor Type 5N, 5F, 5H, pages 15, 17, 18 (Mounts from Gearhead with Feet)

	Product Type	Wt. (lbs.)	XH Length	A Dia-meter	B Motor to Base	C Gearhead Width	D Shaft Length	E Shaft Diameter	F Shaft to Base	G Shaft Detail	H Base Length	H1 Base Width	I Mounting Hole Length	I1 Mounting Hole Width	J Mounting Detail	K Acc'y Shaft	Cord/Lead Length (in.)
<b>Type 5N Gearmotor</b>																	
42R-5N	42R5-5N	15.5	10.103	4.73	5.64	3.568	1.50	.625	1.67	Key/Flat	3.56	3.81	3.00	3.25	[4]ø .271/.266 Holes	No	12
	42A-5N	42A5-5N	14.3													10.198	4.62
34B-5N	34B3-5N	9.0	7.723	4.02	5.26	3.568	1.50	.625	1.67	Key/Flat	3.56	3.81	3.00	3.25	[4]ø .271/.266 Holes	No	12 or 24
	34B4-5N	10.0	8.223													Yes	
	34B6-5N	12.0	9.233													No	
<b>Type 5F Gearmotor</b>																	
34R-5F	34R6-5F	12.0	10.206	4.02	5.28	3.568	1.50	.625	1.67	Key/Flat	3.56	3.81	3.00	3.25	[4]ø .271/.266 Holes	No	12
33A-5F	33A5B-5F	9.9	9.711	3.39	4.96											Yes	24
	33A5F-5F	9.9	9.701													No	
<b>Type 5H Gearmotor</b>																	
48R-5H	48R6-5H	40.0	12.928	5.90	8.07	4.723	2.38	.750	3.000	Key	5.62	6.263	3.875	5.373	[4]ø.41/.44 Holes	No	12
42A-5H	42A7-5H	24.4	12.947	4.26	7.25											Yes	24

Only the first four characters of the product type are relevant to dimensions

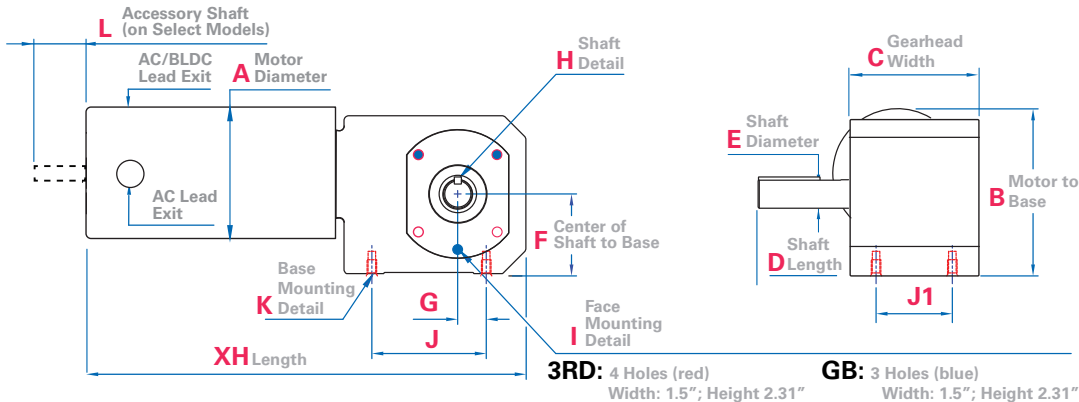

Gearhead Type 3RD, GB, pages 18-19

	Product Type	Wt. (lbs.)	XH Length	A Dia-meter	B Motor to Base	C Gear-head Width	D Shaft Length	E Shaft Diameter	F Shaft to Base	G Shaft to Mounting Hole Center	H Shaft Detail	I Face Mounting Detail	J Mounting Hole Length	J1 Mounting Hole Width	K Base Mounting Detail	L Acc'y Shaft	Cord/Lead Length (in.)
<b>Type 3RD Gearmotor</b>																	
30R-3RD	30R2	9.0	8.140	3.36	4.812	3.60	1.50	.500	1.562	.625	Flat	[4]10-32 UNF-2B x .31 Deep Min.	2.000	2.50	[4]1/4 -20 UNF-2B .31 deep	No	12
	30R4	10.5	8.640														24
24A-3RD	24A2	9.0	8.07	2.42	4.147	3.60	1.50	.500	1.562	.625	Flat	[4]10-32 UNF-2B x .31 Deep Min.	2.000	2.50	[4]1/4 -20 UNF-2B .31 deep	No	24
	24A4	10.5	8.82														12 or 24
22B-3RD	22B2	6.5	8.085	2.378	4.377	3.60	1.50	.500	1.562	.625	Flat	[4]10-32 UNF-2B x .31 Deep Min.	2.000	2.50	[4]1/4 -20 UNF-2B .31 deep	No	12 or 24
	22B4	6.5	9.045														12 or 24
<b>Type GB Gearmotor</b>																	
42R-GB	42R5	17.5	11.458	4.73	5.06	3.335	2.38	.750	2.150	.75	Key	[3]5/16 -18 UNF-2B x .50 Deep Max. on 2.913 B.C.	3.00	2.00	[4]1/4 -20 UNF-2B .40 Deep Min.	No	12
	42R6	19.5	11.893				2.38	.750									[4]1/4 -20 UNF-2B .40 Deep Min.
33A-GB	33A5	13.6	11.067	3.39	4.38	3.335	2.38	.750	2.150	.75	Key	[3]5/16 -18 UNF-2B x .50 Deep Max. on 2.913 B.C.	3.00	2.00	[4]1/4 -20 UNF-2B .45 Deep Max.	No	24
	33A7	14.9	12.268				2.362	.748									[4] M6 X 1-6H .45 Deep Max.
42A-GB	42A5	18.0	11.554	4.26	4.82	3.335	2.38	.750	2.150	.75	Key	[3]5/16 -18 UNF-2B x .50 Deep Max. on 2.913 B.C.	3.00	2.00	[4]1/4 -20 UNF-2B .45 Deep Min.	Yes	24

Hollow Shaft Gearmotor Dimensions

Dimensions (in inches) are for reference only. For CAD drawings and specs, visit [bodine-electric.com](http://bodine-electric.com).

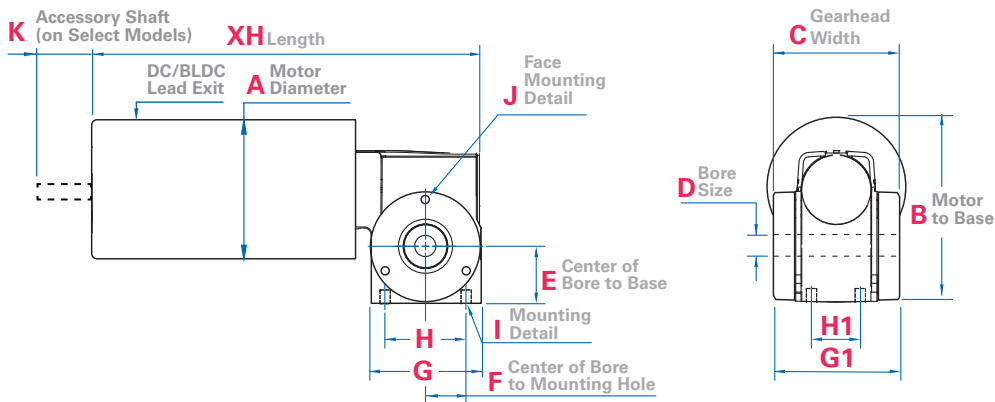

Gearhead Type 3F/H, pages 13-14 (Mounts from Gearhead)

	Weight (lbs.)	XH Length	A Dia-meter	B Motor to Base	C Gearhead Width	D Bore Size	E Bore to Base	F Bore to Mtg. Hole	G Base Length	G1 Base Width	H Mounting Hole Length	H1 Mounting Hole Width	I Mounting Detail	J Face Mount Detail	K Acc'y Shaft	Cord/Lead Length (in.)
24A4-3F/H	5.3	7.422	2.42	3.57	3.085	.502	1.280	1.000	2.56	3.085	2.00	1.188	[4] 1/4 -20 UNF-2B .35 Min. Deep on 2.125 B.C.	Yes	24	
22B4-3F/H	5.4	7.677	2.378	3.80											No	12 or 24
22B4-3F/H INTEGRA	5.4	8.79	2.93	3.823											No	None

Only the first four characters of the product type are relevant to dimensions